

NATIONAL AIR DISASTER ALLIANCE / FOUNDATION

**2020 Pennsylvania Ave. NW #315 – Washington DC 20006-1846
(888) 444-6232-phone – (215) 793-0553-phone – (215) 540-0623-fax**

www.PlaneSafe.org

MISSION: To raise the standard of safety, security, and survivability for aviation passengers, and to support victims' families.

NADA/F, a non-profit organization, with thousands of members worldwide, represents survivors, family members and aviation professionals from over 90 aviation disasters, as well as the traveling public.

Dissenting Opinion:

FAA ARAC Fuel Tank Inerting Harmonization Working Group (FTIHWG)

**Submitted by James H. Hurd, FTIHWG Member, TWA 800, and
NATIONAL AIR DISASTER ALLIANCE/FOUNDATION Board Member.**

Submitted March 13, 2002 at the FAA Aviation Rulemaking Advisory Committee (ARAC) Executive Committee (ExComm) Meeting.

Subject to revisions as a result of additional information from the Working Group.

FTIHWG Participants, Technical Research and Writing by the following:

C. W. Kauffman, Ph.D., University of Michigan, FTIHWG, cwkauff@engin.umich.edu
(734) 936-0104

James H. Hurd, FTIHWG, TWA 800, FAA ARAC ExComm Member and
NADA/F Board Member, cyn29hu@yahoo.com (410) 802-6059

Steven Finley, BOC Gases, FTIHWG, steve.finley@us.gases.boc.com (908) 771-1961

Additional Comments and Research:

Tom O'Mara, NADA/F Board Member, t.j.omara@att.net (651) 464-9595

Gail Dunham, NADA/F President, GADunham@aol.com (215) 793-9224

Introduction

September 2000 an FAA Aviation Rulemaking Advisory Committee (ARAC) was formed in order to provide advice to the FAA about implementing fuel tank inerting (FTI) into center wing tanks (CWT). Their Final Report was issued in June 2001 and submitted to the FAA ARAC Executive Committee (ExComm) in August 2001. Clarifications were requested by the Committee and these will be submitted to the Committee in March 2002. **Both the report and the clarifications are found to be deficient as described in detail below.** It should be noted that this is a second effort to address the fuel tank explosibility issue.

In 1998 the FAA initiated an ARAC study regarding fuel tank inerting in the ullage (empty space with vapors) portion of center wing tanks (CWT). This study was a result of the TWA 800 crash and the National Transportation Safety Board (NTSB) recommendations. This study lasted approximately six months. The findings were that more studies and technology were required and that the cost benefit analysis was not within FAA guidelines.

An explosive mixture of fuel vapors and air will form in the ullage volume of aircraft fuel tanks. A subsequent presence of an active ignition source resulted in a damaging explosion such as the most recent known examples:

- a Boeing 737, Bangkok, Thailand, 2001;
- a Boeing 747, New York, New York, 1996; TWA 800, and
- a Boeing 737, Manila, Philippines, 1990.

Lowering the oxygen content in this ullage volume with nitrogen will prevent these explosions and increase flight safety. A mechanism, which absolutely eliminates the possibility of these fuel tank explosions, is to **reduce the oxygen concentration within the fuel tanks, by increasing the nitrogen content. Any ignition source is then ineffective.**

It should be noted that fuel tank inerting is supported by members of the National Transportation Safety Board (NTSB) and continues to be posted as one of their top ten “Most Wanted” safety improvements. On 8 August 2001, Carol Carmody, acting chair, expressed her disappointment that the FAA (FTIHWG) Working Group relied on cost benefit ratio (CBR) as a basis in recommending that fuel tank inerting not be implemented.

On 23 August 2000, the past NTSB chair, Jim Hall, noted that:

“It is imperative at long last, that the aviation community move with dispatch to remove flammable fuel/air mixtures from the fuel tanks of transport category aircraft as recommended to the FAA by the CAB on 17 December 1963 as a result of the Pan Am flight 214 disaster.”

It is expected that the NTSB can provide to the FAA their information, which supports the inerting of fuel tanks.

The FAA has compiled a list of **27 incidents of fuel tank ignitions**, including fatal explosions from commercial and military flights. See Page 12 of this report for the compilation. It is possible that there are additional incidents or disasters that were not accurately investigated.

Captain Tim Murphy reminded ALPA at its Safety Meeting in August 2001, *“Not all plane crashes are investigated, worldwide.”*

Significant criticism of the concept of cost benefit analysis or ratio is justified, and quantitative data may be chosen which significantly affects these calculations. **It is possible to argue that an immediate program should be initiated in order to inert aircraft fuel tanks, and thus effectively eliminate this explosion danger.**

Cost/Benefit Analysis

The 1998 FTIHWG report stated a cost of \$5B to \$20B over a 15-year period, and the 2001 FTIHWG report stated a cost of \$20B to \$35B over a 15-year period, with no satisfactory explanation for the inconsistencies of their cost benefit analysis. *NADA/F* believes that technical research could demonstrate that lower costs can be achieved with all the scenarios.

- Based upon information available and discussed at the FTIHWG, a normalized charge (cost to the passenger) could be as low as \$.25 per passenger per flight delivered.
- Cost of nitrogen, which is 100% effective in preventing an ignition, could be a charge of \$8.25 for the nitrogen, plus a service charge of \$100 per aircraft per flight.

The basic concept of cost/benefit ratio (CBR) or cost/benefit analysis (CBA) seems to be fatally flawed. The numerical value can be made very large by having a large numerator or small denominator or very small by having a small numerator or large denominator. Having the quantity of the order of unity does not seem to resolve much. More often than not the financial quantities in the Working Group's report are at best estimates, or at worst sheer speculation. Also, some of the assumptions used to justify figures are flawed as explained below.

Within the June 2001 report there are numerous CBR calculations which give the results that the cost of nitrogen fuel tank inerting are greater than the benefits produced. For some of these calculations it is possible to make straightforward comments affecting their validity and/or changing the results to produce a more favorable situation for the implementation of nitrogen fuel tank inerting.

Comments on ARAC FTIHWG 2001 Final Report Dated 6/01/02

1. Pg. 1-7 ¶ 1.8 → Evaluation timeline assumes that it will take 36 months to certify a design and 84 additional months (7 years) to modify the fleet. Figure 1 is a rough cash flow diagram during the evaluation period. The non-recurring costs associated with inerting are realized between 2005 and 2015. Based on pg. 1-8 ¶ 1.8, there is only one expected accident that could be avoided in the 16-year evaluation period. This is due to the fact that no benefit could be realized before the system is implemented. It is suggested that the sensitivity analysis include an earlier implementation date, and/or a longer total time frame.

	2005	2006	2007	2008	2009	2010	2011	2012	2013	2014	2015	2016	2017	2018	2019	2020
Event	Reg. Published			Design Cert							All go					
Cost	↓	↓	↓	↓	↓	↓	↓	↓	↓	↓	↓	↓	↓	↓	↓	↓
Benefit															↑	

Figure 1 – ROM Cash Flows of Cost and Benefit Over Study Period

2. A major assumption that the recently enacted SFAR 88 (Special Federal Aviation Regulation) would reduce accident rates by 75% is not supported by any evidence. Note that no source of ignition has been pinpointed for any of the three most recent explosions. To assume that 75% of these type of accidents can be avoided by inspecting just one of the possible sources is not credible. Further, it has been suggested that this type of manual inspection of wiring harnesses more likely would result in damage of brittle insulation and may increase the likelihood of accidents by creating ignition sources.
3. Page 1-8 2nd ¶ Indicates that only 1 airplane accident would be avoided in the 16-year study. Note that full inerting system capabilities would only be on line for 6 of those 16 years. *(See Page 12 for an FAA list of the 27 incidents of fuel tank ignition, including 13 during the last twenty years.)*
4. Page 1-8 4th ¶ Says 132 deaths avoided for GBI (Ground Based Inerting) and 253 for OBIGSS (Onboard Inert Gas generating System) over the 16-year evaluation period, which is 6 years of system functionality. The benefit over 16 years of operation would be 352 for GBI and 675 for OBIGGS.
5. Accident rates are based on only 3 data points, and therefore do not create a statistically significant pattern. Therefore these rates must represent a fairly low confidence interval. It is suggested that the sensitivity analysis include a range of accident rates that represent higher levels of confidence intervals.
6. Page 1-9 Figure 1-5. Again the benefit interval is only 6 years projected over a 16-year time frame the ratios vary from 14:1 to 20:1.
7. Page 2-2 ¶ 2.b → “Various means of supplying nitrogen (i.e., liquid. . .)” The report does not cover liquid nitrogen supplies. (Note that “i.e.” stands for “that is”, which indicates that they were to specifically look at liquid nitrogen).
8. Page 4-8 ¶ 4.5 → “it was estimated that 15% of avoided accidents would have otherwise occurred on the ground, the other 85% in flight. It was also assumed that 10% of the people would die in a ground explosion, while an in-flight explosion would be a complete loss. . .” These assumptions are not factually or statistically based. The sensitivity analysis should allow for large variation in these estimates. Refer to number 4 above. Over a 16-year period the lives saved are 352 for GBI and 675 for OBIGGS. If we allow that in 100% of explosions there is a total loss, then the numbers become 407 and 780.

	Benefit (\$US billion)	Adjustment for 16 years of benefit	Adjustment for total loss	Cost (\$US billion)	Cost-Benefit Ratio
GBI (HCWT only)	0.245	0.653	0.755	10.37	13.7:1
OBGI (HCWT only)	0.219	0.584	0.675	11.6	17.2:1
Hybrid OBIGGS (HCWT only)	0.257	0.685	0.792	9.9	12.5:1
OBIGGS (all tanks)	0.441	1.176	1.359	20.78	15.3:1

9. If we include the factors from item 8 in the sensitivity analysis, the most favorable scenarios become:

	Scenario from 8/8 Summary Pg#	Benefit (\$US billion)	Adjustment for 16 years of benefit	Adjustment for total loss	Cost (\$US billion)	Cost-Benefit Ratio
GBI (HCWT only)	37	0.281	0.749	0.866	4.196	4.8:1
Hybrid OBIGGS (HCWT only)	43	0.3	0.800	0.925	3.68	4.0:1

10. Page 6-14 → Inclusion of Capital costs may be redundant. It is likely that the operator of the system will absorb those costs, and recoup them via operating costs.

11. Page 11-1 Is the “willingness to pay” value of human life escalated in the out years? If not, then there is another skew in the data. The “willingness to pay” benefit is discounted back to 2005 at 7%. If no escalation was assumed, then the benefits are understated by that 7% discount. Since most of the benefits are in the out years, there is a significant impact. If the adjustments for escalation of benefit are included that changes the most favorable scenario.

12. A major domestic airline disclosed that the actual costs used by the airlines to account for loss of life vary between \$2.7M and \$4.0M based upon the demographics of the airlines route structure.

13. Page G-2, last sentence before Section 2.0 → States “See section 4 for more information about benefits.” No section 4 is included in this report. Please provide missing or removed information.

Numerous examples may be cited of improvements being made within society to increase safety without performing a CBR analysis.

(a) In the Our Lady of Angels, Chicago IL, 1958 school fire resulting in 97 dead, an immediate sprinkler and call box installation was initiated and completed within two years for *all* Chicago schools.

(b) More recently, for the past several years Ford Explorer automotive rollovers, presumably initiated by defective tires, have resulted in over 200 deaths. An expenditure of approximately \$4B has been made by only two corporations as a result of the initial recalls to correct this problem and a second recall valued at \$41.5M has also most recently occurred.

(c) The Ford Motor Company also has an additional problem and is spending nearly \$3B to replace millions of flawed ignition modules. These faulty systems resulted in 11 deaths and 31 injuries.

(d) Additionally, at present there is a massive recall of faulty fire sprinkler heads produced by one manufacturer, Central Sprinkler: the Omega model for residential use, and the GB model for commercial use. It has not been noted that a CBR has been done in order to justify the recall.

In an inverse situation a CBR was calculated by General Motors regarding the safety of fuel systems in automobile crashes. In a recent California jury trial verdict enormous damages, nearly \$4B, were awarded to the injured as General Motors had reportedly decided that the \$8 cost per vehicle required for fuel system redesign and manufacture was not cost effective compared to damages which would be awarded in any subsequent trials.

Finally, the U.S. Supreme Court has in the last term spoke on the issue of CBR. They judged unanimously in an U.S. EPA (Environmental Protection Agency) related case that only public health (substitute the closely related word safety) could be considered and not cost regarding new clean air standards.

Benefit Analysis

As currently structured the benefits chiefly accrue from the figure of \$2.7M which is described by the DOT (Department of Transportation) as the amount “*which U.S. society is willing to spend on increased safety in order to prevent a death.*” It should be stressed that the *NATIONAL AIR DISASTER ALLIANCE/FOUNDATION* does not agree with the DOT economists who have defined \$2.7M as the cost of a life lost in an air crash, or the maximum amount of “*willingness to pay*” for aviation safety and security. History has shown that the American people have *NOT* found this an acceptable amount.

The current very adverse response by the thousands of families suffering from the loss of family members due to the events of September 11th, 2001, and to the provisions of the “Air Transportation Safety and Systems Stabilization Act,” also indicate that this is a very inadequate amount.

Page 4, #8, of this document, references Page 4-8 ¶ 4.5 of the FTIHWG 2001 Final Report: “*it was estimated that 15% of avoided accidents would have otherwise occurred on the ground, the other 85% in-flight. It was also assumed that 10% of the people would die in a ground explosion, while an in-flight explosion would be a complete loss. . .*”

This statement indicates that 90% of the passengers in a ground explosion would be survivors, and potential burn victims. The September 11th burn victims, helped by medical technology of 2002, will have medical bills greatly in excess of \$2.7M per person, plus personal care, compensation for their pain and suffering, and have special needs that we cannot imagine. Indeed, juries and judicial rulings and settlements for air crash survivors, especially burn victims, have been ten times greater than \$2.7M and more. No one would trade places with them for any amount of money, and society wants these victims compensated so that they receive the full support that they need. Industry should be willing to finance higher costs to prevent on board fires and explosions. When the money and technology are there, and have been there for 30 years, the industry should do everything possible to prevent fire and explosions on airplanes.

During a meeting between FAA rulemaking authorities and *NATIONAL AIR DISASTER ALLIANCE/FOUNDATION* members on 28 September 2001, it was indicated by the FAA that this benefit restriction was too limited and that the concept of benefits should be expanded. Such additional benefits should consider the costs of family breakups, which invariably results when a family member is lost. The U.S. government indicates that it has great respect and support for the concept of a small business. A political and legal environment is developed for such to thrive. The family is an ideal example of a small business, and post-air crash conditions should be favorable for the survival of this business.

As the events of September 11th have shown, and as will be applicable to other crashes, air disasters can have other enormous secondary economic effects which need to enter into the benefits calculations. There is the loss of passenger revenue due to fleet grounding and the reluctance of individuals to travel by air. The airlines first response is to lower fares (and profits) when passenger traffic decreases and people do not want to fly. There is decreased use of hotels, restaurants, rental cars, theaters, and all other items related to travel. There may be extensive property loss as a result of an air crash as well as an extensive loss of jobs.

Some quantitative data may be connected to the four airplane crashes on September 11th, which show that the benefits of increased safety have been significantly underestimated in the past.

- \$2T Stock market losses may be estimated (from Milken Review)
- \$15B in air transport losses, or more, **and still growing**
- \$90B for property losses and interrupted business at the Pentagon and New York City (NYC) (per Swiss Reinsurance Co.) OR
- \$105B NYC losses estimated through June 2003 for lost revenue, damage and rebuilding (source NYC Comptroller, and Congressional aids)
- \$30B for the first five months of the War on Terror abroad (recent news)
- \$140B Projected Federal Stimulus Package to prop up the U.S. economy (not including global losses) (“Newsweek,” 10/1/01).
- 32 Boeing airplanes for which struggling airlines might not be able to take delivery (“Wall St Journal” 10/9/01)
- \$0 Financial compensation for some airline executives. Pay cuts and job insecurity industry-wide.
- 1.8M jobs lost in the U.S. by the end of 2002, all as a result of the September 11th aviation disasters.
- No cost estimates for an aviation disaster at a nuclear power facility (Milken Review)

At present, the job loss in the aviation industry alone worldwide stands at 400,000, including an estimated 30,000 job loss for Boeing alone. The cost of the TWA 800 crash is currently estimated to be approximately \$1B. The cost of Swissair 111 is estimated at possibly \$2B, and the airline is no longer in business. The Libyan government has reportedly offered a \$6B settlement with regard to PanAm 103, plus the costs of damages since 1988, and the airline failed to stay in business. A potential casualty of unknown magnitude is the collapse of the insurance and reinsurance market as a result of the aviation disaster losses.

The airline industry is at crisis worldwide, and much needs to be done to re-build faith in the industry. *NADA/F* urges government and the industry to evaluate safety and security recommendations first on their merits to re-build confidence in the aviation industry. The

American people are not accepting known fatal flaws and safety and security contracted to the lowest cost bidder.

At the 28 September 01 meeting at the FAA with NADA/F, the economist stated that he had not imagined multiple accidents in a single day. We cannot afford for the industry to ignore that possibility ever again.

As a result of the next such aviation disaster punitive damages of unknown amounts may be awarded to families suffering the loss of members. On 17 August 01, \$400+M in damages were awarded against Cessna Aircraft Co. regarding an alleged known defect concerning the failure of seat positioning locks.

The information above would indicate that the dollar amount attributed to benefits could and should be increased significantly, thus substantially decreasing the figure for the CBR.

The June 2001 ARAC Final Report does put the air transport industry on notice that there is a known single point failure mechanism which will produce a catastrophic fuel tank explosion. The report also indicates that the nitrogen inerting of fuel tank ullage is 100% effective in eliminating fuel vapor/air explosions within aircraft fuel tanks. A known hazardous condition may be eliminated.

In other scenarios, where nitrogen-generating systems are considered, the small amount of information which is available in the unclassified world would seem to indicate that current military technology, if available for use, could also lower the cost estimates. The military has been using fuel tank inerting for over 30 years, and their classified information could be helpful.

Ignition Source Control

Benefits Attributed to SFAR 88 (Special Federal Aviation Regulation)

The FTIHWG determined that the benefit of ullage inerting should be reduced to reflect the benefits offered by new procedures defined by SFAR 88. The SFAR was released as the Working Group was assessing the benefits of inerting, and these benefits were discounted considerably (75%) based on the assumption that the process defined in the SFAR would yield significant benefits.

"The 75% reduction had been estimated by the 1998 FTIHWG." [**FTIHWG Final Report Pg. H-9**]

The benefits offered by SFAR 88 are difficult to quantify, because many of the ignition sources for fuel tank explosions have not been identified as noted by the FAA [**Federal Register May 7, 2001 pg. 23127**]

"As noted, the FAA has not quantified the potential benefits from this final rule because there is uncertainty about the actual ignition sources in the two fuel tanks..."

Further the regulatory text in **SFAR 88** calls for reducing the exposure to flammable mixtures. From **§25.981(c)**:

"The fuel tank installation must include either--

1. Means to minimize the development of flammable vapors in the fuel tanks (in the context of this rule, "minimize" means to incorporate practicable design methods to reduce the likelihood of flammable vapors); or
2. Means to mitigate the effects of an ignition of fuel vapors within fuel tanks such that no damage caused by an ignition will prevent continued safe flight and landing."

The FTIHWG assumed a 75% reduction in fuel tank explosions resulting from the implementation of SFAR 88, however, has this included the reduction of flammability exposure specified in the regulatory text for SFAR 88?

A **fuel/air explosion** (FAE) occurs when five items come together:

- fuel,
- oxidizer (oxygen),
- ignition source,
- confinement, and
- vapor phase fuel/oxidizer mixing.

The first three are commonly known as the fire triangle while all are known as the explosion pentagon. For the latter situation the removal of any one item precludes an explosion, but the attempted control of only one component, such as ignition sources, is a risky strategy. It may decrease the number of incidents, but it will not eliminate them. Experiences in other industries such as the process, coal mining, and grain and feed have shown that it is necessary also to control the fuel in order to eliminate fuel/air explosions.

It is exceedingly difficult to have two failures at the same time — ignition sources and combustible fuel/air mixture. Such a strategy was adopted by another segment of the transportation industry, maritime petroleum shipping, where the scrubbing of tankage led to an electrostatic ignition source for the fuel vapor/air mixtures. An analysis of the problem led to the use of stack gases as an oxidizer diluent within the empty tanks.

Nonconventional ignition sources have become of increased concern.

- Silver components within the fuel tank through chemical reactions occurring in the presence of low sulfur fuel can produce conducting paths leading to short circuits.
- On 26 November 1989 an Avianca B-727-100 crashed shortly after takeoff from Bogota, Columbia as a result of the detonation of an explosive device placed in a seat on the starboard side of the passenger cabin, which in turn ignited fuel vapors in an empty fuel tank.

- On 22 December 2001, an American Airlines 767-300, Flight 63, traveling from Paris, France to Miami FL, was diverted to Boston MA. A passenger sitting in a port side window seat slightly aft of the wing trailing edge had attempted to detonate an explosive device which had been hidden in his shoes. Had the initiation attempt been successful and had he been located above the center wing tank he may have ignited, with fatal results, the fuel vapors in the center wing tank.
- January 1995 responding to a routine fire alarm in a Manila apartment building, firemen and investigators uncovered a bomb-making factory with electronic timers and terrorist plans regarding near-future transpacific flights. The timers matched those used to explode a bomb on a Philippines airline flight of a few weeks earlier, which killed one passenger and forced an emergency landing. The eleven long haul flights, all with intermediate stops on a single day, designated as imminent targets involved mainly those of United and American Airlines, the same airlines targeted for September 11th. The explosive technique of operation Bojinka of placing a small bomb within the cabin certainly could have been enhanced by locating it over the center wing tank and detonating it later into the flight when its liquid fuel had mostly been consumed.

As with the case of the Avianca and American Airlines flights, SFAR88 would not have decreased the likelihood of these intentional ignition sources.

In the process, coal mining, and grain and feed industries unanticipated/unexpected ignition sources led to the failure to eliminate explosions by the control of ignition sources exclusively. It will be the same situation regarding SFAR88. It is thus impossible to definitively quantize its effect and not to implement a second backup strategy such as nitrogen fuel tank inerting.

Related Safety Issues

It is not realistic to try to inert the fuel tanks in all aircraft at all locations within the global aviation network at the same time. A risk and consequence analysis needs to be performed relating to the different types of aircraft so as to propose an intelligent implementation of an inerting program.

Logic would dictate that one would begin with the high risk, heated center wing tank (HWCT) aircraft currently in production or to be put into production. Those to be neglected would be ones of smaller capacity near the end of their airframe life. Geographically, the initiation would occur at airports with the largest passenger traffic and last implementation would be those with little passenger traffic.

Any **cost associated with the implementation of fuel tank nitrogen inerting** must be normalized in a rational fashion. This is not an enormous one-time expense which will be paid for by the air transport industry. Just like any other expense it will be passed on to the passengers.

1. Based upon information available to and discussed by the Working Group, such a normalized charge could be as low as \$0.25 per passenger per flight delivered.
2. There could be a charge of \$8.25 for the nitrogen plus a service charge of approximately \$100 per aircraft per flight.

- Even now, when fuel prices are at an all time low, the airlines are authorized to charge a fuel surcharge for each ticket of \$18.60 one way, and \$37.20 round trip. The surcharge was added when the price of Jet A fuel was at a maximum, and may still be charged to the customer.
- Passenger Facility Charges (PFC's) can be a maximum of \$4 (plus tax) per airport, with a maximum of \$20 (plus tax) per ticket, and the PFC's continue to increase.
- The domestic transportation tax is 7.5% per ticket, and billions have accumulated in the federal Aviation Trust Fund.
- The new security tax is \$2.50 one way and \$5 round trip, or with multiple segments can be \$10 round trip per ticket.
- The International Transportation Tax used to be \$3 per round trip ticket, and now round trip international taxes can be \$200+ per ticket. International ticket taxes continue to increase in the number of taxes, and the amount of the tax, or service charge, or user fee.

Such an expense of \$.25 per passenger per flight, or \$100+ for nitrogen, per airplane, per flight is literally peanuts in comparison to the cost of the ticket, taxes, and service charges. Since September 11th passengers have not complained about the security tax, and have expressed that they are willing to pay for higher levels of safety and security.

Conclusions

The combustible fuel vapor and air mixture which appears in the ullage of HCWT's (heated center wing tanks) during a certain period of flight time, 33%, represents a safety risk. Nitrogen inerting eliminates this risk for a very minimal cost. The modification of the air transport system to implement this procedure may be done in a very intelligent, controlled manner. As the events of September 11th have shown, air crashes have many unforeseen consequences, and the air travel system has shown itself to have limited elasticity. The next HCWT explosion may well have extensive foreseen and unforeseen consequences. **A measured, determined introduction of the nitrogen fuel tank inerting technology is imperative beginning immediately in order to enhance aviation safety.**

The following is the FAA compiled list of incidents of fuel tank ignitions from the Federal Register: April 3, 1997 (volume 62, Number 64) Page 16013-16041

www.epa.gov/fedrgstr/EPA-GENERAL/1997/April/Day-03/g8495.htm

Commercial Fuel Tank Explosions:

	Model	Operator/Location	Year	Fatal	Hull loss
1	B707	OSO	1959	4	Yes
2	B707	Elkton	1963	81	Yes
3	B707	San Francisco	1965	0	Yes
4	B727	Southern Air Transport, Taiwan	1964	1	No
5	B727	Minneapolis	1968	0	No
6	B727	Minneapolis	1971	0	No
7	DC-8	Toronto Canada	July 1970	106	Yes
8	DC-8	Travis AFB	1974	1	Yes
9	DC-9	Air Canada	1982	0	Yes
10	Beechjet 400	Jackson MS	June 1989	0	No
11	B727	Avianca	1989	107	Yes
12	B737	Philippine Airlines	1990	8	Yes
13	B747	TWA 800	July 1996	230	Yes
14	B737	Thai Airlines	2001	1	Yes

Military Non-Combat Fuel Tank Explosions:

1	B52	Loring AFB Maine	July 1970	0	Yes
2	B707	USAF Spain	June 1971	Yes	Yes
3	B52H	Minor ND AFB	Nov. 1975	0	Yes
4	B747	Iranian Fuel Tanker	1976	7	Yes
5	KC135Q	Plattsburg AFB NY	Feb. 1980	Not Noted	Yes
6	B52G	Robins AFB Georgia	Aug. 1980	Yes	Yes
7	KC135A	Near Chicago	March 1982	Yes	Yes
8	B52G	Grand Forks AFB ND	Jan. 1983	Not Noted	Yes
9	KC135A	Altus AFB OK	Feb. 1987	Yes	Yes
10	B52H	Sawyer AFB MI	Dec. 1988	Yes	Yes
11	KC135A	Loring AFB Maine	Sept. 1989	Yes	Yes
12	KC135A	Loring AFB Maine	Oct. 1989	Yes	Yes
13	KC135R	Mitchell Field, Milwaukee WI	Dec. 1993	Yes	Yes

Total 27

Glossary

Basic Inerting design systems:

GBI **Ground Based Inerting** – A system using ground-based nitrogen gas supply equipment to inert fuel tanks that are located near significant heat sources or that do not cool at a rate equivalent to unheated wing tanks. The affected fuel tanks would be inerted once the airplane reaches the gate and is on the ground between flights.

OBGI **Onboard Ground-Inerting** – An onboard system that uses nitrogen gas generating equipment to inert fuel tanks that are located near significant heat sources or that do not cool at a rate equivalent to an unheated wing tank. The affected fuel tanks will be inerted while the airplane is on the ground between flights.

OBIGGS **Onboard Inert Gas Generating System** – A system that uses onboard nitrogen gas generating equipment to inert all the fuel system’s tanks so that they remain inert throughout normal ground and typical flight operations.

Derivative combinations of OBGI and OBIGGS were also studied, and were described as “**hybrid systems.**”

ARAC Aviation Rulemaking Advisory Committees

CBA Cost Benefit Analysis

CBR Cost Benefit Ratios

FTIHWG Fuel Tank Inerting Harmonization Working Group

SFAR Special Federal Aviation Regulation

The following Comments for Liquid Nitrogen On-Board Storage and Cost Benefit Analysis are being submitted on behalf of those who contributed Technical Research and Writing to the dissent.

Comments on ARAC Final Report CBA for Liquid Nitrogen On-board Storage

In the June 2001 ARAC FTIHWG Final Report sixteen different scenarios are considered in order to assess the cost. In scenario sixteen what could be one of the most promising concepts, an onboard cryogenic (liquid) nitrogen system, is considered as a result of a request made by the ARAC Executive Committee at its April 2001 meeting to the Working Group. The CBR as calculated by the Working Group is not favorable. However, alternative calculations presented below are much more favorable.

The term "*practicable design methods*" may have been interpreted by the FTIHWG to exclude the inerting concepts (Scenario 1 to 16) reviewed and deemed not be cost effective. However, the analysis of Scenario 16 appears to be incomplete and inaccurate. Their CBA was based on a number of assumptions, which are detailed in the Estimating and Forecasting team's final report in Section 3. The following assumptions are under question:

- (1) "*Gas generating systems are less expensive and less hazardous*"
- (2) "*The computed LN₂ weight is based on carrying enough LN₂ for three flights*"
- (3) "*The system described above has been sized to inert all fuel tanks on the airplane*"
- (4) "*Weight in Figure G-64 based on FAA study "Performance of a DC-9 Aircraft Liquid Nitrogen Fuel Tank Inerting System" (1972)*"
- (5) "*A mechanic; not a ground service worker is required to fill the airplane storage tanks.*"
- (6) "*All nitrogen needed would be generated at the airport*"
- (7) "*All retrofit costs based on the costs of the GBI airplane system.*"
- (8) "*Although the closed-loop oxygen sensing system is more complex than an OBIGGS, it was assumed the maintenance and delay costs would be similar*"

Many of the assumptions made either do not apply or should be restated to reflect the realities of the system proposed at the ExComm meeting of April 2001.

A concept has been developed using liquid nitrogen to generate gaseous nitrogen with purity in excess of 99.9% to maintain a non-flammable ullage in airplane fuel tanks. The primary advantage of liquid nitrogen storage is the ability to convert a large volume of nitrogen gas from a substantially smaller volume of liquid. The ratio of gas volume to liquid volume for nitrogen is 696:1. The system concept employs a liquid nitrogen (LN₂) storage vessel or dewar, which is designed for use on aircraft. The LN₂ is vaporized to nitrogen gas and delivered through a simple manifold to the ullage of the aircraft fuel tank. The pressure in the dewar is controlled at a low pressure by a pressure-reducing valve. In the event of over-pressure or failure of the primary relief valve, a safety device (rupture disk) opens to vent nitrogen gas outside the aircraft beyond. The flow of nitrogen gas is controlled by the ullage flammability, which determined by the combination of oxygen concentration and ullage temperature. This method of control limits

nitrogen usage to only the portions of the flight profile that require inerting to mitigate flammability. Measurement of oxygen concentration is the only means available to determine with certainty that the ullage is inert. While adding to the complexity of the overall system, an oxygen sensor ensures effectiveness of any inerting system, while conserving nitrogen. The internal pressure of the dewar (less than 5 psi) is adequate to deliver the nitrogen through the control valves, to the ullage manifold. The design uses very little power, due to the use of dewar pressure for delivery of the nitrogen gas. The only power required for this design is for the solenoid valve and instrumentation, approximately 1 kW.

Assumptions (from FTIHWG Final Report)

(1) "Gas generating systems are less expensive and less hazardous than liquid nitrogen based systems"

The nitrogen gas generating systems evaluated by the FTIHWG all required a complex array of compressors, heat exchangers, filters, valves, water separators and air separation modules or distillation columns. The cost of equipment for each system is in excess of \$180K. In addition, connections to a bleed air source as well as substantial power requirements lead to very high installation costs. The liquid nitrogen based system offers a significant reduction in the number and complexity of components. The cost of equipment as proposed is to be included in a service fee charged by the inerting service provider. For a moment, make a comparison between cryogenic nitrogen and aviation fuel. We do not load crude petroleum on the aircraft for onboard refining into jet fuel. The refinery would weigh too much and consume too much power!

*Installation costs are expected to be paid by the same parties as for the other 15 Scenarios, however, these costs must be substantially lower as the only connections required are for the ullage manifold, the vent and the electrical system (instrumentation only). While it is understood that costs in categories (e.g. engineering, setup) are similar, the cost for hardware and installation for the liquid nitrogen based system will be considerably lower than the others considered. The assumption made by the Estimating and Forecasting team is inaccurate. **The same process of estimating costs (e.g., figure F-A2, etc.) must be made for the liquid nitrogen based on-board design as for the others.***

The asphyxiation hazard attributed to nitrogen inerting is taken very seriously by the industrial gases industry, and any system offered would unquestionably be assessed for the risks. Beyond well-structured safety procedures and training, safety interlocks can be included in the design without adding significantly to the complexity of the system. Interlocks provide protection even when operators and maintenance personnel ignore safety procedures. Normal airline maintenance procedures for accessing enclosed spaces (i.e. fuel tanks) require the area to be purged to remove hydrocarbon vapors. This process is likely enough to mitigate the risk of asphyxiation; however, the oxygen concentration can be checked easily before entry. The oxygen sensors included with the inerting system can control a latch to prohibit access when the oxygen level is too low. In addition, inexpensive (approx. \$300) hand held oxygen sensors can be used to increase the level of safety. This design and these procedures are very common in industry today.

(2) "The computed LN2 weight is based on carrying enough LN2 for three flights"

The design of the liquid nitrogen system can provide for adequate storage for three flights, however, this may be necessary only for medium sized aircraft, which often have quick turn times and several trips per day. In contrast, large aircraft have longer turn times, and often only fly one trip per day. Some sizes specified by the FTIHWG are considerably larger than necessary. For example, the weight of LN2 specified in their analysis (1,282 lbs.) generates enough nitrogen gas to inert the equivalent of over 131,000 gallons of ullage space. In light of turn times associated with large aircraft, and length of flights, is it necessary to carry so much nitrogen? **The FTIHWG should consider whether it is necessary to require capacity for three flights across all airframe sizes.**

(3) "The system described above has been sized to inert all fuel tanks on the airplane"

The Tasking Statement [Federal Register: July 14, 2000 (Volume 65, Number 136)] states that *"The system shall inert all fuel tanks with an on-board nitrogen gas generating system..."*. This is inconsistent with the requirements for Ground Based Inerting, which states that *"The system shall inert fuel tanks that are located near significant heat sources or do not cool at a rate equivalent to an unheated wing tank..."*. **Please clarify the differentiation in requirements for the two modes of inerting.**

(4) "Weight in Figure G-64 based on FAA study "Performance of a DC-9 Aircraft Liquid Nitrogen Fuel Tank Inerting System" (1972)"

The FTIHWG's report referenced data from a report that is 30 years old. Advances in storage of liquid nitrogen may have had a favorable impact on the weights and costs associated with liquid nitrogen storage. Based on equipment available today, the weights were updated and are reflected in Figure G-64 (re-stated) below. Limiting the amount of liquid nitrogen stored on-board may also offer the benefit of reducing the size and weight, and to a lesser extent, the fuel penalty. A 100-gallon Dewar carries enough liquid nitrogen to inert over 69,000 gallons of ullage space. The vessel weighs only 475 lbs. Additional components include pressure-reducing valves, pressure relief valve, solenoid valve, oxygen analyzer, thermocouples and piping are anticipated to weigh no more than 100 additional lbs. The weight of the distribution manifold specified in the Ground Based Inerting Team's report (Pg. C-26, Figure 13.0-1) is 54 lbs. **The FTIHWG should redress their estimates of weights associated with liquid nitrogen based on-board inerting designs evaluated as Scenario 16 (Pg. G-66).** The following table represents revised estimates of weights shown on Figure G-64:

	Large Airplane			Medium Airplane			Small Airplane		
	Cu-Ft N ₂	Weight	Gal	Cu-Ft N ₂	Weight	Gal	Cu-Ft N ₂	Weight	Gal
LN ₂	9,311	675	100	4,655	338	50	2,328	169	25
Storage, controls, wt		575			375			300	
Plumbing		54			34			22	
Total		1,304			747			491	

Figure G-64 (re-stated) Liquid Nitrogen System Weight (all fuel tanks)

(5) "A mechanic; not a ground service worker is required to fill the airplane storage tanks."

A nitrogen service contractor can conduct the process of filling the airplane storage tanks. Two methods of executing this process are foreseen:

- (a) Fill on-board LN₂ storage tanks located through a unique external connection located on the airframe (similar to the process fueling the aircraft)
- (b) Replace empty vessels with full vessels, which have been filled and tested off-line by nitrogen supply contractor.

It is proposed that the service provided by the nitrogen supply contractor include:

- Supply and maintain liquid nitrogen storage vessels along with ancillary components; including valves, instrumentation, and pressure regulators.
- Fill vessels with liquid nitrogen as required.
- *Design, test, and certify liquid nitrogen inerting package excluding fuel tank distribution manifold.*

This can be offered on a fee basis, requiring no investment in equipment. The fee includes all items defined above with little or no initial capital investment. Anticipated cost for the service is less than \$200 per turnaround, which occurs once every two to three flights.

In **Item A** above, the design of the on-board inerting system utilizing liquid nitrogen requires a connection from the LN₂ storage vessel to a unique, frangible fitting located outside the airframe, in a location accessible to the ground based nitrogen service contractor. A design similar to the proposed by the Ground Based Inerting Design team could be adapted easily for cryogenic service. The nitrogen contractor would utilize operators trained in the delivery of liquid nitrogen and airport operations to transfer liquid nitrogen from their storage vehicle to the on-board vessel. A similar process is safely conducted hundreds of times a day for a wide range of industries, albeit not in an airport environment.

The vessel will be filled at a local liquid nitrogen manufacturing facility located near the airport facility.

In **Item B**, it is foreseen that the storage vessel will be an integrated, removable system including all valves and instrumentation, excluding the oxygen analyzer. The nitrogen contractor will be

responsible for maintaining and testing the equipment as well filling them in their facility located near the airport. Vessels requiring replacement will be removed from the airplane and replaced with a filled unit that has been tested. The process of changing liquid nitrogen vessels will be conducted by personnel trained in safe handling of cryogenic equipment; specifically for the airline industry.

Changing cylinders has an added advantage of ensuring that the inerting system is operational prior to a flight. The procedure will include a full check of the storage system at the nitrogen contractor's facility; therefore not affecting turn times. The failure rate of this design will be extremely low. In the rare event of failures, replacements will always be on hand, as the equipment becomes standard ground equipment. The design of the inerting system is such that the change can be made quickly, safely and dependably. Special mounting and connection hardware will be used to ensure this.

The FTIHWG should re-calculate the costs of inerting when inerting service is provided at a cost of \$200 per use every two flights, three flights.

(6) "All nitrogen needed would be generated at the airport"

There are a number of manufacturers of liquid nitrogen serving industries throughout the world. A network of Air Separation Units (ASU) separate air into its three main components: nitrogen, oxygen, and argon using a distillation process. At ASU's a subsequent process called *liquefaction* converts the gases to liquid for more efficient storage. As a liquid, nitrogen and the other industrial gases can be transported to customers within a 200-mile radius cost effectively. When the delivery truck arrives, the liquid nitrogen is transferred to the customer's storage tank. It is extremely rare for customers to need to generate liquid nitrogen on their facility. Only when the quantities are extremely large, does it make sense to generate liquid on site. Typical ASU's serve hundreds of customers over a wide geography. Even the largest airports will not use enough liquid nitrogen to economically justify a dedicated ASU. Existing liquid nitrogen manufacturing capacity is anticipated to be adequate to serve airport needs in the U.S.

There is a wide-ranging network of industrial gas distributors who store liquid nitrogen, oxygen argon and others to serve industries like welding. Liquid nitrogen is available virtually anywhere in the United States; either through manufacturers or distributors. **Appendix C** illustrates the network of liquid nitrogen, oxygen and argon throughout the United States. The distributor network is not shown.

The proposed solution does not require liquid nitrogen to necessarily be present at every airport facility. Since the design provides inerting for multiple flights, servicing can be scheduled by airlines at a select number of airports (e.g. Hub airports) to minimize the overall cost of implementation. In addition, the process can be scheduled during slow periods, for example overnight to further reduce the impact of inerting. **The FTIHWG should consider the use of on hand nitrogen production facilities for the supply of liquid nitrogen and determine the cost under that circumstance.**

(7) "All retrofit costs based on the costs of the GBI airplane system"

It is not necessary to replicate the GBI design for the liquid nitrogen based design. If **Item 5A** were used, the GBI design could easily be adapted to facilitate liquid nitrogen delivery to the on-board storage vessel. However, **Item 5B** requires no external connection to facilitate delivery of liquid nitrogen. In this case, the cost of adding an external connection along with associated fittings, valves and monitors will not be required.

The design of the manifold should be redressed in light of the results of the FAA tests on a scale model (DOT/FAA/AR-01/6). Results from testing at the Technical Center indicate that the manifold design may be greatly simplified, reducing engineering expense and weight, with equivalent results to the GBI Design team's proposed design.

(8) "Although the closed-loop oxygen sensing system is more complex than an OBIGGS, it was assumed the maintenance and delay costs would be similar"

Oxygen sensors provide the only reliable means of confirming whether ullage is inert. The designs offered by the on-board and ground based design teams do not offer oxygen sensors. The consequences of this decision include over-compensating for lack of information by purging with substantially more nitrogen than required. Beyond unnecessary nitrogen cost and time spent with the inerting process, this solution increases emissions of hydrocarbons by a factor of at least three; though often more than that when full CW tanks are involved.

Inclusion of an oxygen analyzer in the design considerably reduces the volume and time needed to maintain an inert ullage. The system will use oxygen and temperature information to determine flammability, and deliver nitrogen gas only when the conditions warrant nitrogen to limit flammability.

A design using liquid nitrogen storage would be far less complex than any OBIGGS system proposed, simply due to the fact that integration into an aircraft's power systems and bleed air are not required with the liquid nitrogen design. With the removable vessel option (Item 5A), maintenance procedures will be conducted off the aircraft, and procedures associated with inerting can be conducted every two to three flights in a process slightly more complex than baggage handling.

The FTIHWG should assess the benefit offered by oxygen analyzers with the on-board inerting system in contrast to the cost of complexity.

The FTIHWG should also conduct a comparable analysis of the liquid nitrogen based on-board inerting concept.

As both food and fuel are furnished by independent contractors to the air carriers it would seem reasonable that nitrogen should also be furnished in this manner at a substantially lower cost than is calculated in the final report.

This one example shows that the dollar amount associated with costs may be lowered, thus decreasing the value of the CBR. And, this scenario is of special interest in that it burdens the aircraft only with the weight and volume of the inerting material which is produced and delivered by those expert in the process.

Appendix A

An Alternative to OBIGGS

A solution has been developed for on-board inerting that directly addresses the issues raised by the FTIHWG's final report. In the report, the FTIHWG recognizes the safety benefit of on-board inerting in comparison to ground based inerting. The recommendation specifies that alternative technologies should be assessed which offer the safety benefits, but at lower cost and power consumption. One alternative offered to the FTIHWG, but not given serious consideration was the use of liquid nitrogen dewars for storage on board, with an automatic distribution system tied into the fuel tank's ullage. There are a number of benefits offered by such a design, which were not made clear in the FTIHWG's report:

- *Substantial improvement in reliability over OBIGGS, which requires rotating equipment including a compressor.*
- *Substantial reduction in power requirements*
- *Ability to service a range of flow requirements*
- *Employment of higher purity nitrogen, therefore, about half the flow requirement*
- *Control of ullage based on flammability as oxygen sensors are included in the design*
- *Ability to redirect nitrogen flow for cabin fire suppression*

The power required to generate on-board nitrogen utilizing all of the three OBIGGS designs considered is unacceptable for today's fleet according the final report from the FTIHWG. It is well established that a significant amount of power is required for all modes of nitrogen generation, including pressure swing adsorption, air separating membranes and cryogenic distillation. While the concept of generating nitrogen on demand is appealing to the airline industry, the reality exists that this comes at a cost; specifically limited power resources on aircraft.

All modes of air separation require compressors to raise the pressure of the air being separated. In the case of pressure swing adsorption, differences in pressure are used to enable sieve material to separate nitrogen from air, then release impurities; specifically oxygen during lower pressure cycles. Pressure is required in membrane systems to drive oxygen and other impurities through the polymeric membrane material allowing higher purity nitrogen to pass through the air separation modules ASM. Finally, cryogenic distillation requires very high pressure to generate the high expansion rate required to cool air to cryogenic temperatures required for separation.

In all three cases, compressors are required to drive the separation process. Compressors have two serious issues associated with them as spelled out in the FTIHWG's report; reliability and power.

Liquid nitrogen used on-board, does not carry these burdens. As indicated above, manufacture of liquid nitrogen does require a considerable amount of power; in fact more than what is required for the three technologies discussed above. The differentiating factor, however, is that the power does not need to be provided on the aircraft.

Liquid nitrogen is supplied to a wide range of industries through a network of Air Separation Units (ASU) spread throughout North America and the rest of the world. Once made, liquid nitrogen can be stored in specially insulated vessels for weeks at a time. Thousands of businesses have their nitrogen delivered as a liquid and store it in these vessels so they can use the liquid or vaporized nitrogen gas as needed. The same concept is practical for the airline industry; albeit with special considerations.

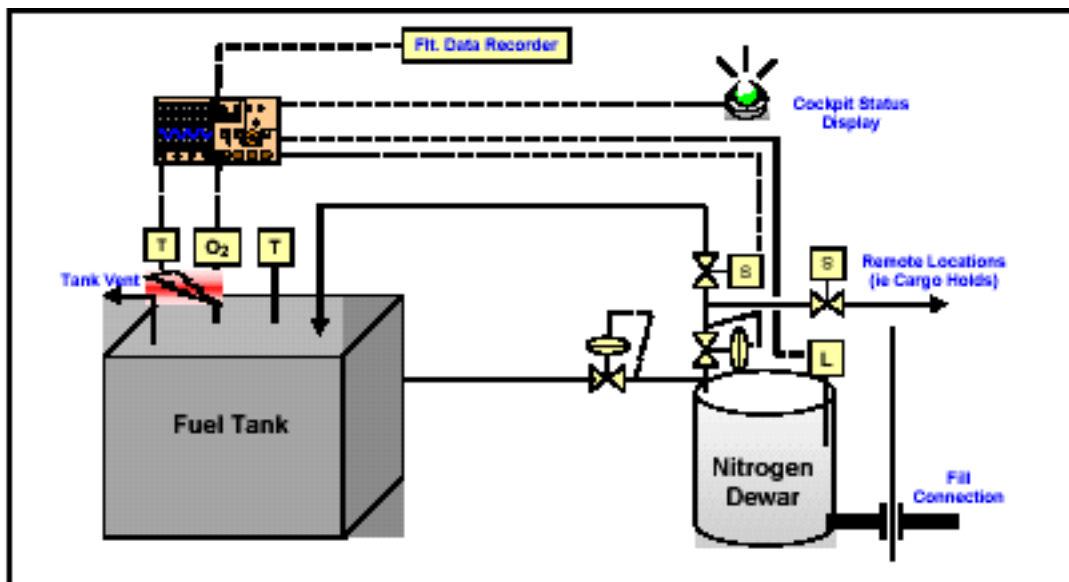

Liquid nitrogen has a purity of 99.997%, therefore the amount of nitrogen required for inerting is reduced substantially. The OBIGGS systems discussed in the FTIHWG report generate nitrogen with a purity of 95%. The volume of nitrogen required using lower purity nitrogen is about 75% higher than would be required for liquid nitrogen. It is argued that the cost of inerting with higher purity nitrogen is lower than for lower purity (see "The Effect of Nitrogen Purity on Ullage Washing" below).

Appendix B

The Effect of Nitrogen Purity on Ullage Washing

Nitrogen generators can deliver a wide range of flow and purity. As a general rule, the unit cost for nitrogen decreases as the flow requirements increase and the unit cost increases as the purity increases. The cost of nitrogen is also sensitive to energy costs and atmospheric conditions. It is normally assumed that the added cost of higher purity nitrogen (98 to 99% N₂) is cost prohibitive compared to the less expensive nitrogen in the 95 to 96% purity range. Analysis of nitrogen costs over a range on purity has found that the opposite is true. When the total cost of inerting is considered, higher purity nitrogen provides lower cost ullage washing, while reducing the time required to inert and reducing fuel vapor emissions resulting from the process. The following represents the results of the analysis which was derived from purge calculations and a matrix of nitrogen costs.

Figure 1 represents the range of costs for nitrogen generated on site (either membrane or PSA) as a function of the average flow requirement in std cu-ft/hr. The curves illustrate that the unit cost for nitrogen (\$ per 100 cu-ft) steadily decreases as the average flow requirements increase. The curve only represents a trend, which is affected by the selection of equipment and the usage pattern. Equipment offered by industrial gas suppliers cover a range of flows. The efficiency of the equipment can vary depending on which part of the operating curve the equipment is operating. The most economic selection of nitrogen generating equipment can be made by the industrial gas manufacturers, and are typically offered as leased equipment.

The prices cover a wide range, due to variations in equipment cost, and purity. The prices shown below assume a cost of \$.075 per kW-hr. Higher or lower electrical rates will affect the cost. The costs represented above do not include liquid nitrogen.

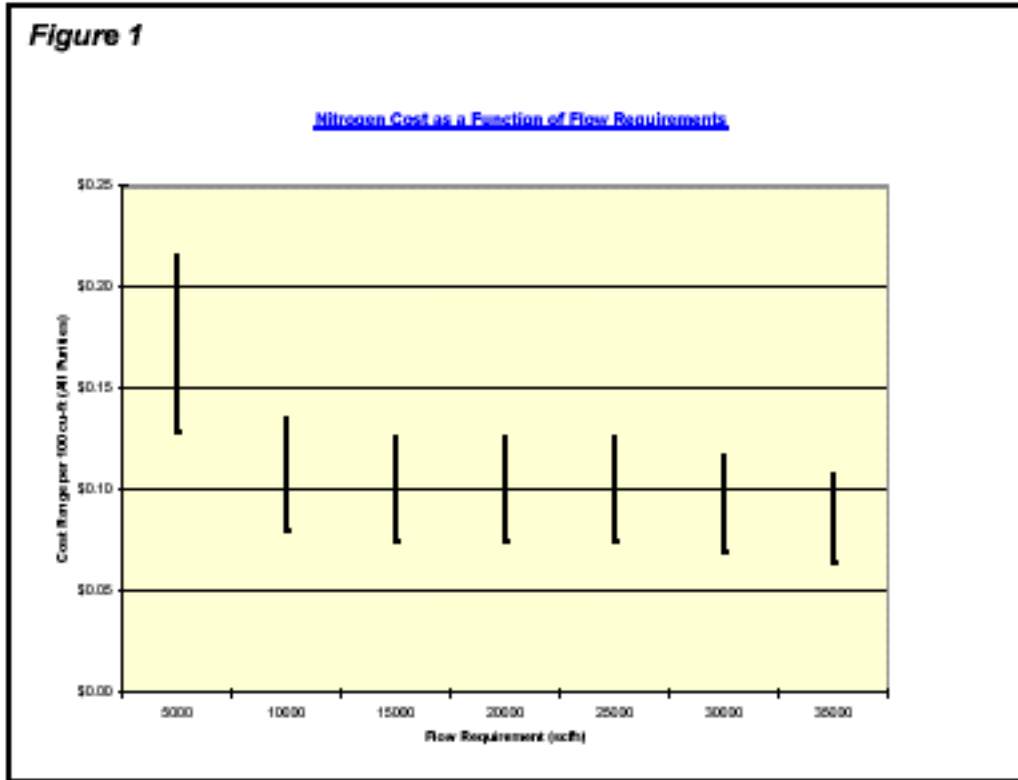

Figure 1. Nitrogen Cost as a Function of Flow Requirements

Figure 2 shows the effect that purity has on nitrogen cost. For every purity value, a range of costs is shown to reflect flow requirements as well as equipment lease costs. It can be seen that the cost of nitrogen increases as the purity level increases. To generate nitrogen of higher purity, either larger equipment is required or the energy requirements are higher due to the demands of the higher purity cycles. Often the same generating equipment can produce nitrogen at a range of purity levels at a sacrifice of energy or capacity. The unit cost for nitrogen is affected in either case.

The value of nitrogen in inerting applications increases considerably as purity increases. There is a significant reduction in the nitrogen volume requirement for high purity compared to low purity nitrogen. Inerting flow is often expressed as volume of inerting nitrogen required for a given ullage volume (V/V) or the number of equivalent ullage volumes of nitrogen required to inert the ullage. The definition of inert varies considerably from application to application. For ullage washing, 8% O₂ is the target concentration.

Test data have indicated that the risk of flammability for Jet-A fuel is insignificant below 10% O₂. As a practical matter, the Ground Based Design team has determined that the target O₂ concentration for ground based inerting is 8%. As there is a delay between the inerting process and takeoff, 8% ensures that the ullage will remain inert throughout the initial stages of the flight cycle.

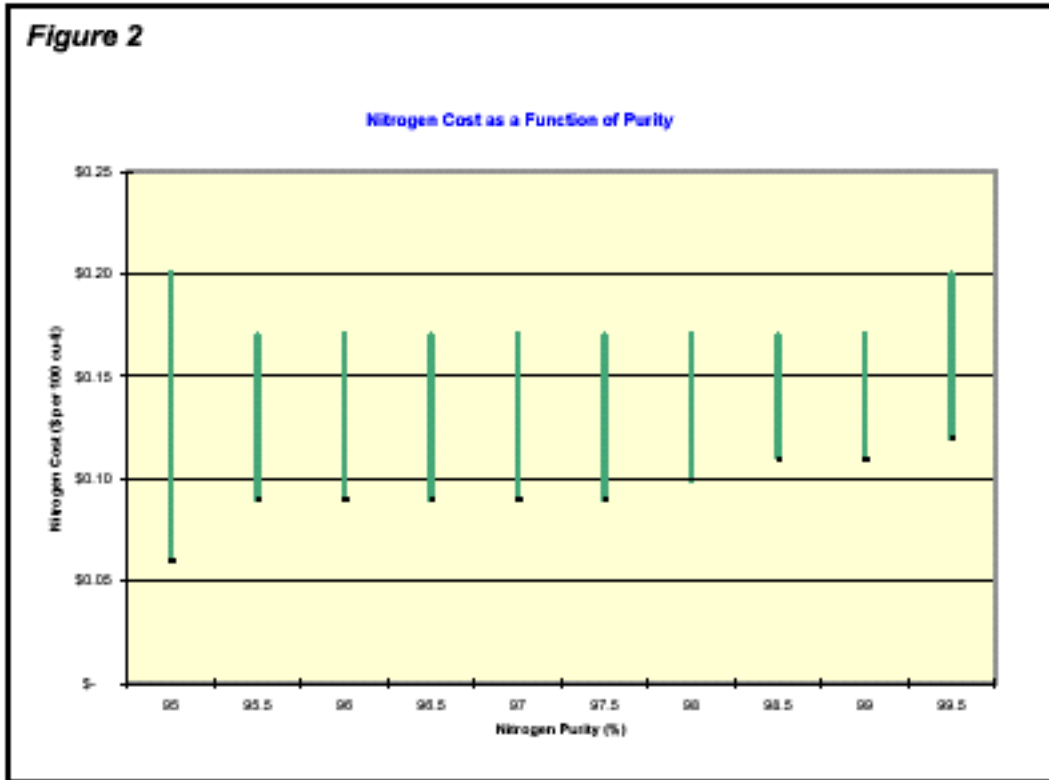

Figure 2 Nitrogen Cost as a Function of Purity

The theoretical volume of gas required to inert the ullage will be a function of the ullage O₂ concentration prior to inerting, the target O₂ concentration and the O₂ concentration of the nitrogen used to inert.

The relationship between nitrogen purity and volume required is represented by a logarithmic curve. The following formula is used:

$$n = \ln\left(\frac{C_o - C_p}{C_t - C_p}\right)$$

where

- n = number of ullage volumes of N₂ required for purge
- C_o = Initial Oxygen concentration in ullage (%)
- C_t = Final (or target) Oxygen concentration in ullage (%)
- C_p = Oxygen concentration of purge gas (%)

Figure 3 represents the relationship between purge gas purity and the equivalent ullage volume in standard cu-ft required to reduce the O₂ concentration from 21% to 8% for an ullage of 100 std cu-ft

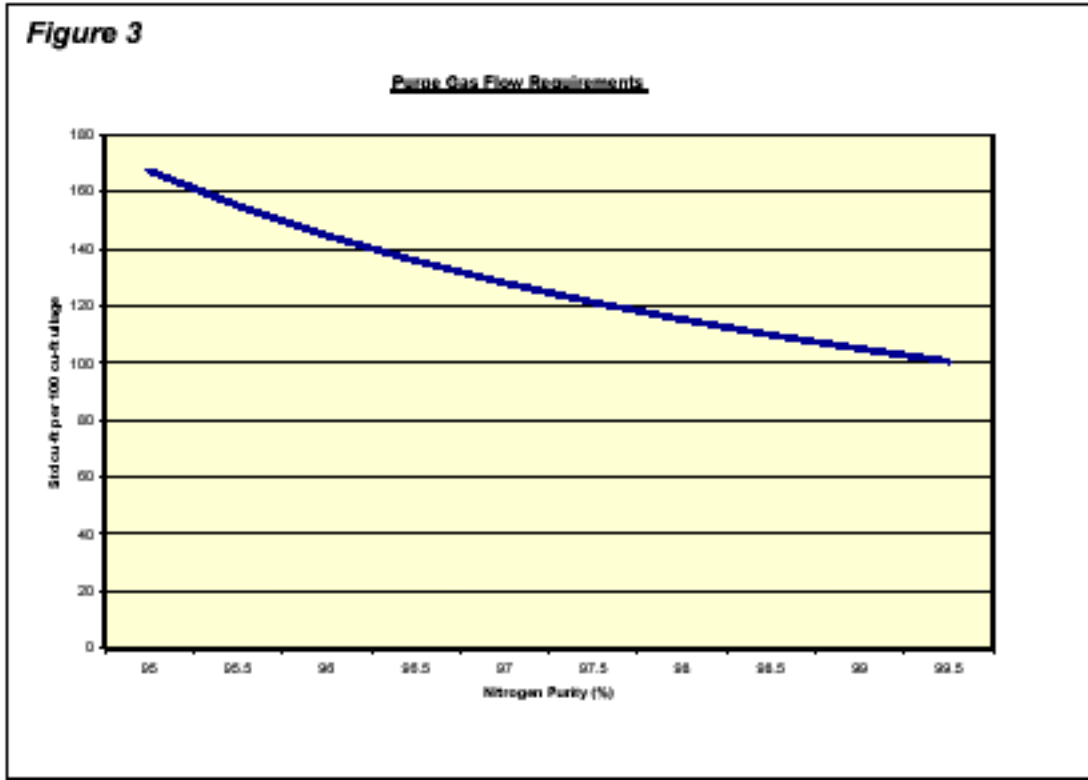

Figure 3 Purge Gas Flow Requirements

The curve shows that when the purge gas is 95% approximately 170 cu-ft of purge gas is required to inert a 100 cu-ft ullage. On the other extreme, only 100 cu-ft is required to inert the same ullage to 8% using nitrogen with a purity of 99.5%. This represents a 41% reduction in purge gas volume required. The added benefit of higher purity nitrogen offsets the added cost as **Figure 4** illustrates. The curve represents the theoretical volume requirement assuming efficient mixing of the inerting gas with the ullage. Typically, the efficiency of the inerting process is less than perfect and is affected adversely by such factors as geometry, purge nozzle configuration and location and the vent location. As a general rule, actual purge gas requirements can be expected to exceed the theoretical volumes.

It is shown in **Figure 4** that the cost of inerting actually decreases as the purity of nitrogen is increased. Comparing the minimum costs shown for each purity, the cost to inert a 100 cu-ft ullage with 95% nitrogen is \$0.18 versus \$0.12 when nitrogen of 99% purity is used. The difference in cost is attributed to the significant reduction in nitrogen required. The plot represented in **Figure 4** was created by multiplying the required volume of nitrogen required (from **Figure 3**) by the cost per cu-ft (from **Figure 2**).

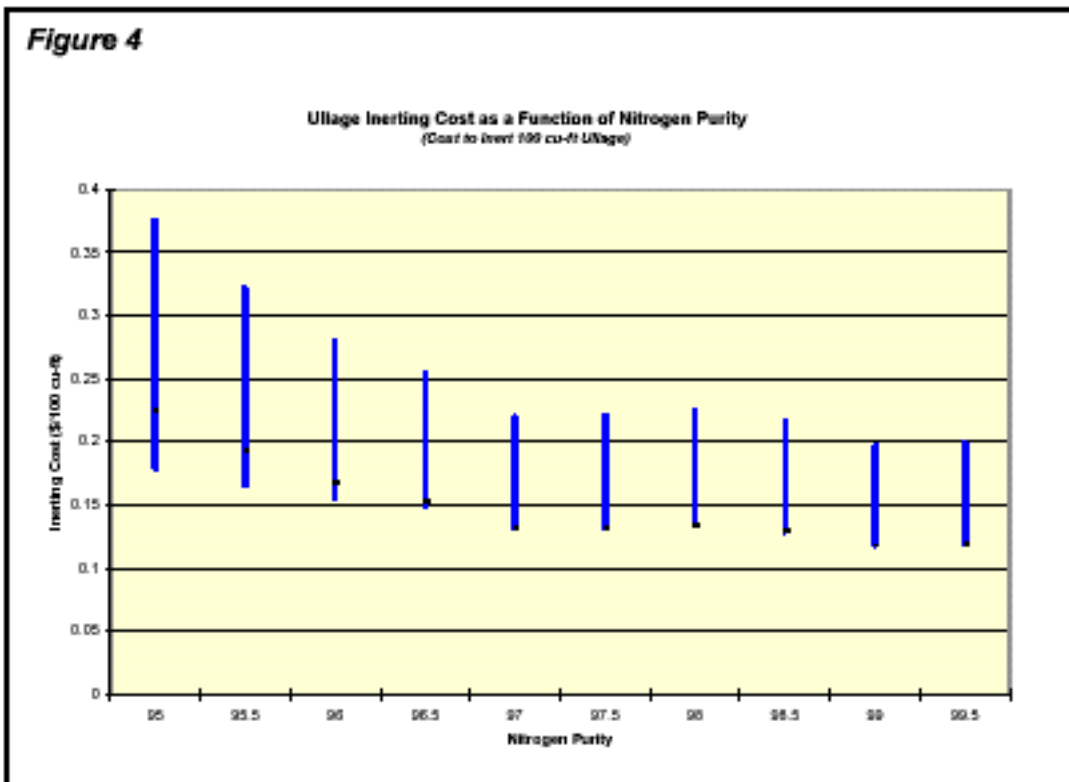

Figure 4 Ullage Inerting Cost as a Function of Nitrogen Purity
(Cost to Inert 100 cu-ft Ullage)

For a given flow rate, higher purity nitrogen has the added benefit of reducing the amount of time required to inert an ullage space. The family of curves shown in Figure 5 shows the effect nitrogen purity has the time required to inert. Each curve represents inerting time as a function of purity. The time to inert was determined using the Ground Based Design team's equipment design basis of 251 scfm. Three curves are used to represent the classifications of aircraft identified by the ARAC to represent the groups of aircraft subject to the inerting procedure.

The first aircraft group, identified as "Commuter" represents the average fuel tank size for commuter aircraft. In this case, the average fuel tank is 3,000 gallons for an equivalent tank volume of 401 cu-ft. The inerting time using 95% nitrogen is 3 minutes, 24 seconds. Using 99% purity, the inerting time is 2 minutes, 6 seconds.

The next curve represents inerting time for the group identified as "Medium Transport" or "Single Aisle" Aircraft. For this group, the average tank size was assumed to be 10,000 gallons or 1,337 cu-ft. The inerting time ranges from 8 minutes 57 seconds using 95% nitrogen to a low of 5 minutes, 36 seconds using 99% nitrogen.

Finally, the "Large Transport" or "Wide Body" aircraft class has an average fuel tank capacity of 25,000 gallons or 3342 cu-ft. The range of times required for inerting goes from 22 minutes 23 seconds using 95% purity nitrogen to 14 minutes, 2 seconds using 99% nitrogen.

The value of reducing the amount of time required to inert fuel tanks has not been quantified, however, the Ground Based Inerting Design team included among its assumptions that the process will not affect turn time. The design for aircraft accommodates the flow rates specified in this document. To reduce the volume of nitrogen required for inerting, and thus the time required nitrogen purity could be increased from the originally proposed 95% to 99%. The benefits are threefold; lower cost, reduced time to inert and reduced emissions.

In addition, the volume and time can be further reduced by inerting only the ullage. The curves above assume inerting with a volume equivalent to the volume of an empty fuel tank. This greatly simplifies the process, and decreases the likelihood that errors can be made. In many cases, however, nitrogen is wasted, the process takes considerably longer than necessary, and fuel vapor emissions are increased substantially.

Properly inerting the fuel tank to address only the volume of the ullage can be done if the oxygen concentration of the ullage is measured. Oxygen analyzers added to the fuel tank or at the fuel tank's vent can provide a reasonable estimate of the oxygen concentration in the fuel tank. Knowing the oxygen concentration can significantly reduce the nitrogen requirement, and in addition provide a direct measurement of the effects of inerting.

The overall cost of inerting fuel tank ullage is driven by a number of factors including the flow rate, purity, method of supply, nitrogen cost and ullage volume. The analysis of this matrix of data has determined that higher purity nitrogen provides the most cost effective purge gas. Nitrogen can be generated at airport facilities at the full range (95 to 99%) of purity analyzed using membrane generators or Pressure Swing Adsorption (PSA) generators. The design for the distribution manifold and supporting components specified for retrofit of aircraft will limit the flow rate and pressure available for the inerting process. As turn time and cost become more critical, there are alternatives to optimize the process including higher purity nitrogen and oxygen measurement.

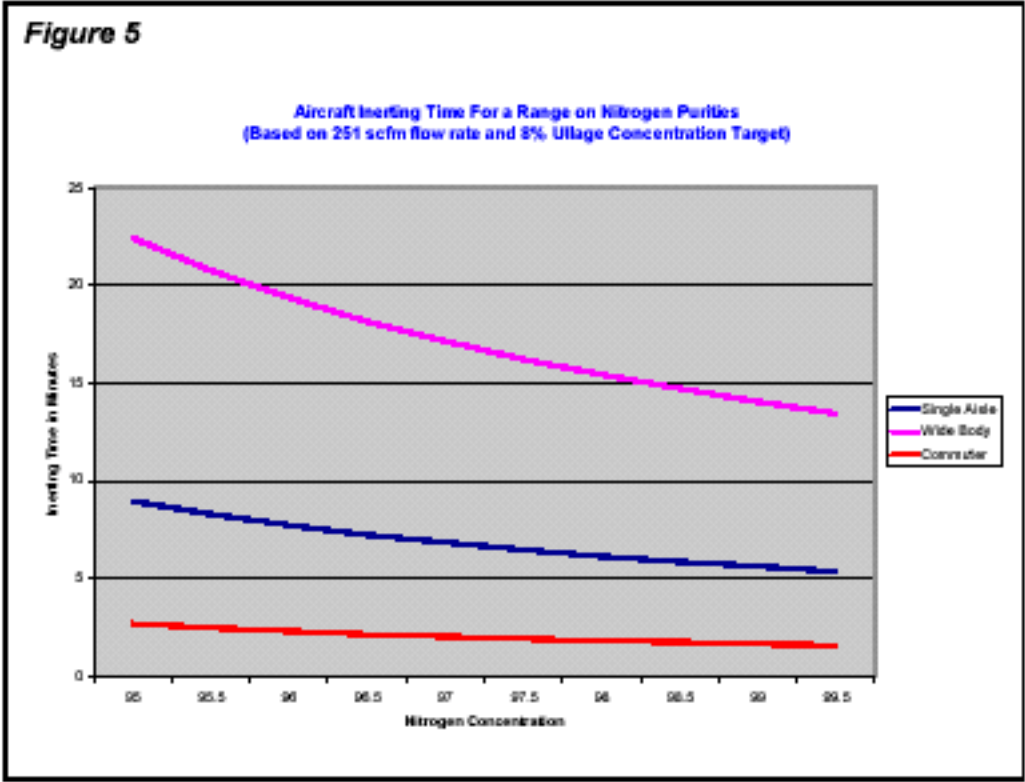

Figure 5 Aircraft Inerting Time For a Range on Nitrogen Purities
 (Based on 251 scfm flow rate and 8% Ullage Concentration Target)

Appendix C

ASU Plant Locations for all Industrial Gases Companies USA

